

**SCANIA**

**16:07-02**

Issue 1 **en**

# Communication problems

## Help when troubleshooting

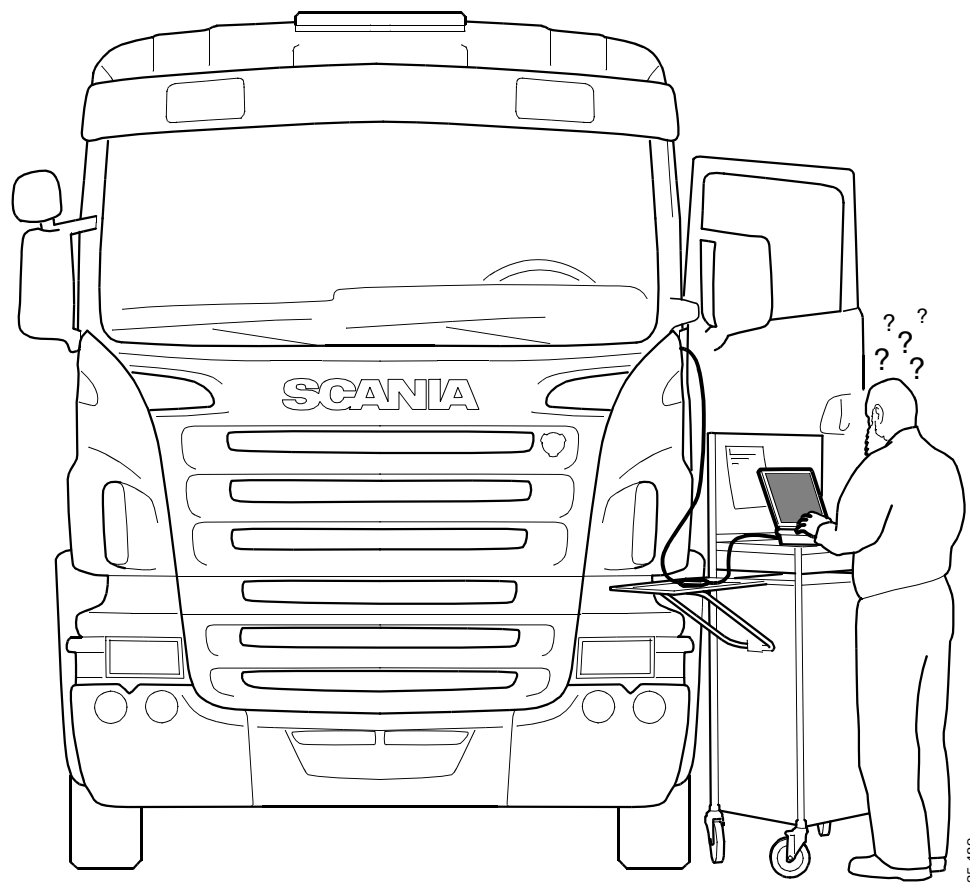

135 489

# Contents

Background .....	3
Troubleshooting	
Preparations .....	4
SDP3 cannot establish contact with the vehicle .....	5
SDP3 can only establish contact with systems on the green CAN bus .....	8
Communication problems in the vehicle .....	9
CAN chart .....	10

# Background

An electrical system with CAN communication implies to some extent a new way of carrying out troubleshooting, compared with a conventional electrical system.

In most cases it is possible to carry out troubleshooting within the vehicle electrical system using SDP3. This assumes that communication between the control units via CAN cables is working and that SDP3 can communicate with the vehicle control units.

In some cases faults may occur which can be difficult to diagnose using SDP3.

Examples which may assist you when you are searching for the causes of faults in the vehicle's electrical system are provided below.

More detailed information about the electrical system can be found in the booklet Electrical system in P, R and T series, Introduction and general troubleshooting.

The methods of measurement for the green CAN bus which are described in the booklet can also be used to troubleshoot the yellow CAN bus and red CAN bus.

# Troubleshooting

## Preparations

Before you start, you should know whether the fault occurred in connection with some other activity, e.g. connecting bodywork, installing accessories, etc. or whether it just occurred for no apparent reason.

For troubleshooting you need:

- SDP3
- Multimeter
- Chart showing how the control units are connected to the CAN bus (see last page)
- Measuring adapter 99 508 (included in measuring adapter kit 99 511)
- Fault code descriptions

If SDP3 cannot communicate with one or more control units so that you cannot obtain supplementary numbers or fault codes within the program, you can obtain a list of fault codes for each supplementary number from SDP3 as follows:

Go to the menu under **View** and select **Search for fault code list**.

You can obtain the supplementary number via the IVD function on the instrument cluster, provided that the instrument cluster can establish contact with the control units and that fault codes have been registered.

The instrument cluster always shows which systems it expects to receive a response from, i.e. which systems are fitted on the vehicle.

If there are no fault codes registered in the control unit, the instrument cluster displays:

**"no errors"**

If the instrument cluster cannot establish contact with the control unit, it displays:

**"no contact"**

In this case, however, it is not the fault codes that are most important, since it is the communication we want to test. If the instrument cluster responds with "no errors", this means that communication is working. Systems such as CTS (clock and timer system), AHS (auxiliary heater system) and AUS (audio system) must be switched on in order to establish contact with them.

## SDP3 cannot establish contact with the vehicle

When the program is started, a fault message appears indicating that the program cannot find any SOPS. When you enter the program, it is "empty".

- 1 Check that VCI2 is connected.

### Function of the lamps

PWR (green)	The lamp lights up continuously when the VCI2 is supplied with voltage both from the vehicle and the PC.  The lamp flashes when the VCI2 is connected to the PC.
USB (yellow)	The lamp lights up (flashes rapidly) when data is transmitted between the PC and VCI2 via the USB key.
CAN (yellow)	The light lights up (flashes rapidly) when data is transmitted between the VCI2 and the vehicle via the CAN bus.
Error (red)	The lamp lights up when there is a communication error on the CAN bus.

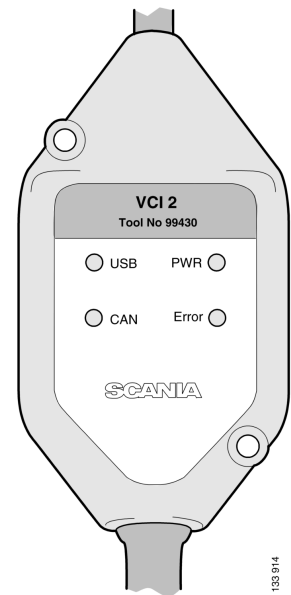

- 2 Try to start the program again.
- 3 Check using the IVD function on the instrument cluster (diagnostic mode) whether the ICL control unit can communicate with systems on the green CAN bus.

**N.B.** On low-specification vehicles, it is not certain whether there will be any systems on the green CAN bus.

Check via the instrument cluster which systems should be available on the vehicle and compare them with the CAN chart on the last page.

- If the ICL control unit has established contact with the green CAN bus, check whether there is an open circuit somewhere between the VCI2 and the junction box for the green CAN bus (C479).

- If the ICL control unit has not established contact with the green CAN bus, continue troubleshooting as follows:

The junction blocks are concealed and located on the right of the central electric unit area. They are fitted in the holes without locking, which means that they can easily be taken out.

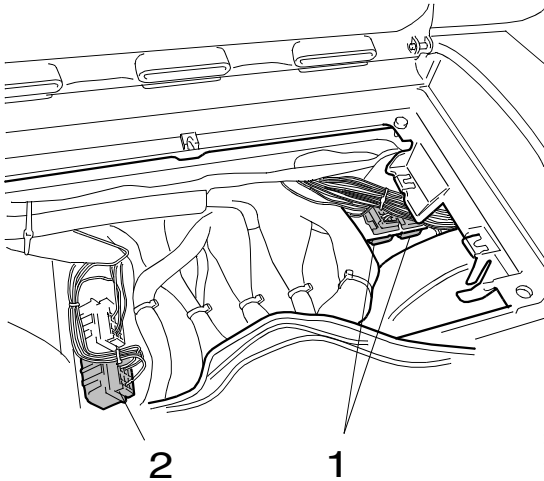

- 1 Junction blocks for CAN
- 2 Junction block for earth.

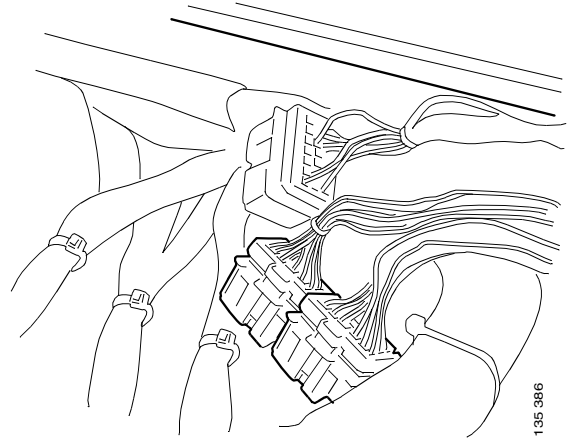

*Junction blocks taken out.*

- 1 Measure the voltage level between chassis earth and the green CAN bus using a multimeter.
  - The voltage should be approximately 2.5V

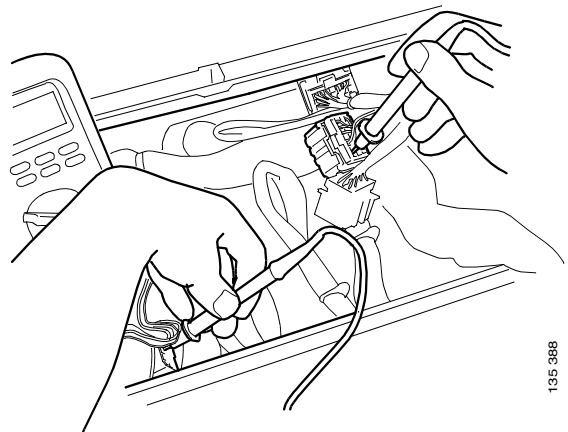

*Example of measuring on CAN high in relation to chassis earth.*

**Note!** During the following measurement, all systems must be connected but not supplied with voltage.

- 2 Measure the resistance on the CAN cable between CAN high and CAN low.
  - The resistance should be around 60 ohms.
  
- 3 Measure the resistance between CAN high and chassis earth or between CAN low and chassis earth to check that the resistance is high enough.
  - The resistance should be at least 1000 ohms, in most cases it is much more.
  
- 4 If the resistance is too low, disconnect the connector and measure on the junction box for the green CAN bus for all cables in order to find out which control unit is faulty.
  
- 5 Disconnect the control unit concerned in order to determine whether there is a fault on the control unit or in the cable harness.
  
- 6 If there is a fault in the cable harness, troubleshoot according to the instructions set out in "Electric system in P, R and T series, Introduction and general troubleshooting".

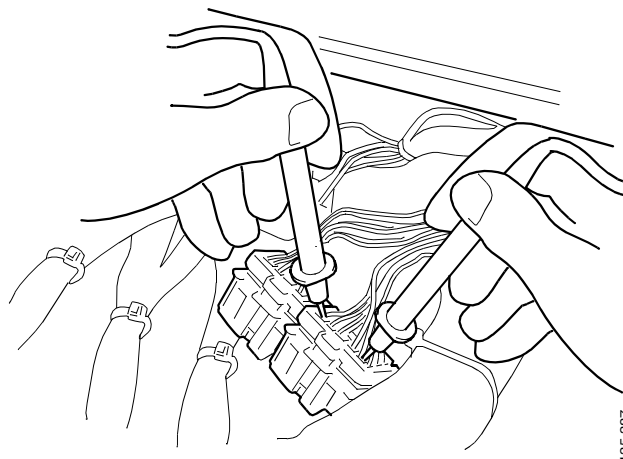

135 387

*With the junction blocks taken out, it is easy to measure, e.g. the resistance between CAN high and CAN low.*

## SDP3 can only establish contact with systems on the green CAN bus

The ICL control unit has only established contact with systems on the yellow (its own) CAN bus.

- 1 Check the voltage supply to the coordinator.  
Start by checking that the fuse for the coordinator (fuse 19) is intact and that voltage is supplied to it.

**IMPORTANT!** To avoid damaging the pins, you should use the measuring adapter. No measurement should be carried out directly on the coordinator pins because they are very sensitive.

- 2 Check using measuring adapter 99 508 whether the coordinator is receiving voltage to pin connection 3 (30-supply) and pin connection 81 (15-supply).

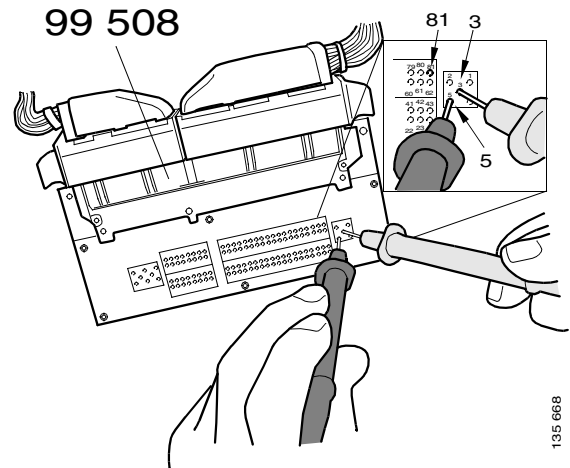

*Measurement on pin 3 (30-supply)*

- If the measurement shows that voltage is being supplied to the coordinator, the cause may be play in the coordinator connector.

- 3 Test by connecting the coordinator again.

- If the fault persists, renew the coordinator.
- If the fault disappears, inspect the relevant pin in the connector and renew it if necessary.



## Communication problems in the vehicle

Faults which may cause the vehicle to engage "limp home mode". All possible warnings come on in the instrument cluster.

- If you can use SDP3, check the fault codes. Also check whether there are inactive fault codes which cause problems at low voltage.

If you cannot use SDP3, try to read the fault codes from the instrument cluster.

- If a control unit has a fault code for a low supply voltage, measure the input voltage and check the control unit earth connection by, for example, measuring the voltage drop on the earth lead.
- If there are fault codes implicating a specific CAN bus, test by measuring the voltage on the CAN bus by connecting a multimeter between the CAN high cable and chassis earth.

The voltage should be approximately 2.5V.

- If the multimeter shows an absurdly high value, more than 5V, this may indicate earthing problems on one or more control units on the CAN bus which is being measured.
- Dismantle the junction block and check what is giving the incorrect voltage.
- Check any earthing problems by measuring the voltage drop on the control unit. Measure from the earth connection in the control unit connector to a safe earthing point, e.g. one of the cab earthing points. Correctly operating earthing results in no or very little voltage drop.

# CAN chart

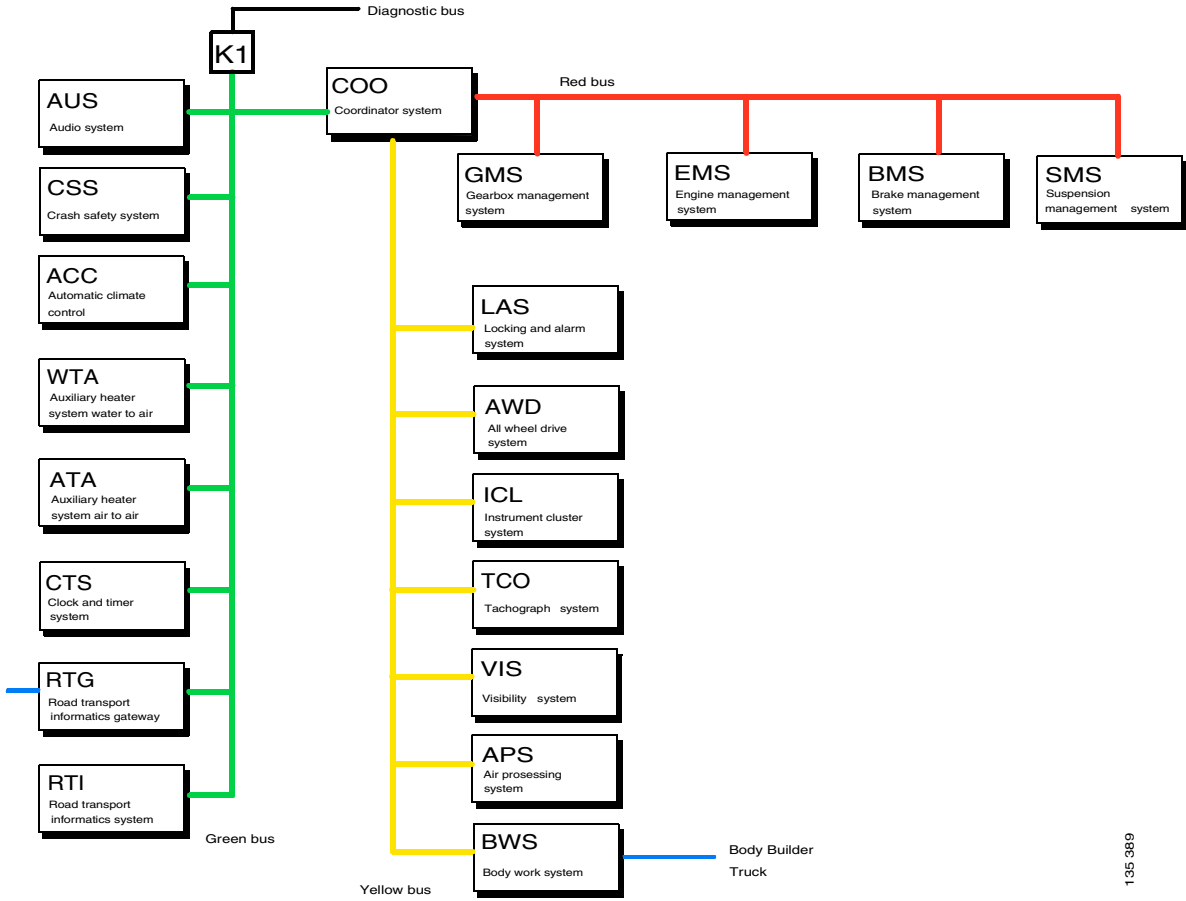

135 389